

225.02821-CPR-2020.10.05

Utført av JSK - Godkjent for produsent av Tomasz Taczyński og Dag Riise 05.10.2020

<b>Produkt:</b>	<b>Antenne-Kamera mast 380 7m to-delt</b>
<b>Produkt nummer:</b>	<b>22512023807</b>
<b>Påtenkt bruk:</b>	Mast for kamera, antenne eller annet utstyr
<b>Harmonised Standard:</b>	PN-EN 1090-1:2009+A1:2011
<b>Produsent/ Plassert på markedet av:</b>	Saferoad Traffic AS Paul A. Owrens veg 46, 2607 Vingrom, Norway
<b>Produsert på fabrikk:</b>	SAFEROAD Pomerania Sp. z o.o. Stanisława Dubois 23, 71-610 Szczecin, Poland
<b>Utførelsesklasse:</b>	EXC2
<b>Teknisk spesifikasjon: Harmonisert standard NS-EN 1090-2: 2009+A1:2011</b>	Toleranser: <b>NS-EN 1090-2, klass 1</b>
	Sveisbarhet: <b>S355J2 i henhold til EN10025-2</b>
	Slagseighet: <b>S355J2: 27J ved temp. -20°</b>
	Avgivelse av Kadmium: <b>NPD</b>
	Utstråling av radioaktivitet: <b>NPD</b>
	Bestandighet: <b>HDG iht. to SS-EN ISO 1461, klass Fe/Zn 115µm</b>
	<b>Konstruksjonsegenskaper:</b>
	Utmatningskapasitet: <b>Ikke analysert</b>
<b>Brannmotstand: NPD</b>	
<b>Produksjonsgrunnlag:</b>	Tegningsnr.: 10002821
<b>Montering:</b>	Masten leveres i to deler som monteres sammen med medfølgende bolter. - se tegning på side 2. Maksimal lokal referansevindhastighet: 28m/s. (TK = II) Maksimal høyde over havet: 500m hoh. => Maksimal vindlast = 1,06 kN/m <sup>2</sup> Ref. Vind iht. NS 3491-4 / NS-EN 1991-1-4: Følgende utstyr kan maksimalt monteres på masten Maksimalt ekv. areal av utstyr montert på toppen: 0,5 x 0,5 x 0,5m Maksimal vekt av utstyr montert på toppen: 80kg Maksimalt ekv. areal av utstyr montert på siden: 0,4 x 0,2 x 0,2m Maksimal vekt av utstyr montert på siden: 30kg Maksimal areal av kabler: 40mm Maksimal høyde klatrehinder: 3m (maks. 20% dekning av areal)
<b>Drift / Vedlikehold:</b>	Intet vedlikehold er påkrevd
<b>Systemer for vurdering og kontroll, CE merking: :</b>	Portalen er CE merket iht NS-EN 1090-1:2009+A1:2011, se vedlegg. <b>Notified Body nr. 2627, TÜV Rheinland Polska.</b> System for attestering av samsvar iht. CPR, Annex V: System 2+
<b>Varig merking:</b>	<b>Varig merking på hver seksjon/del:</b> <b>Øvre del: 02821STÅÅSP####-2</b> <b>Nedre del: 02821STÅÅSP####-1</b> <b>ÅÅ = Produksjonsår, #### = SP internt order nr.</b>

225.02821-CPR-2020.10.05

Utført av JSK - Godkjent for produsent av Tomasz Taczyński og Dag Riise 05.10.2020

## Montering:

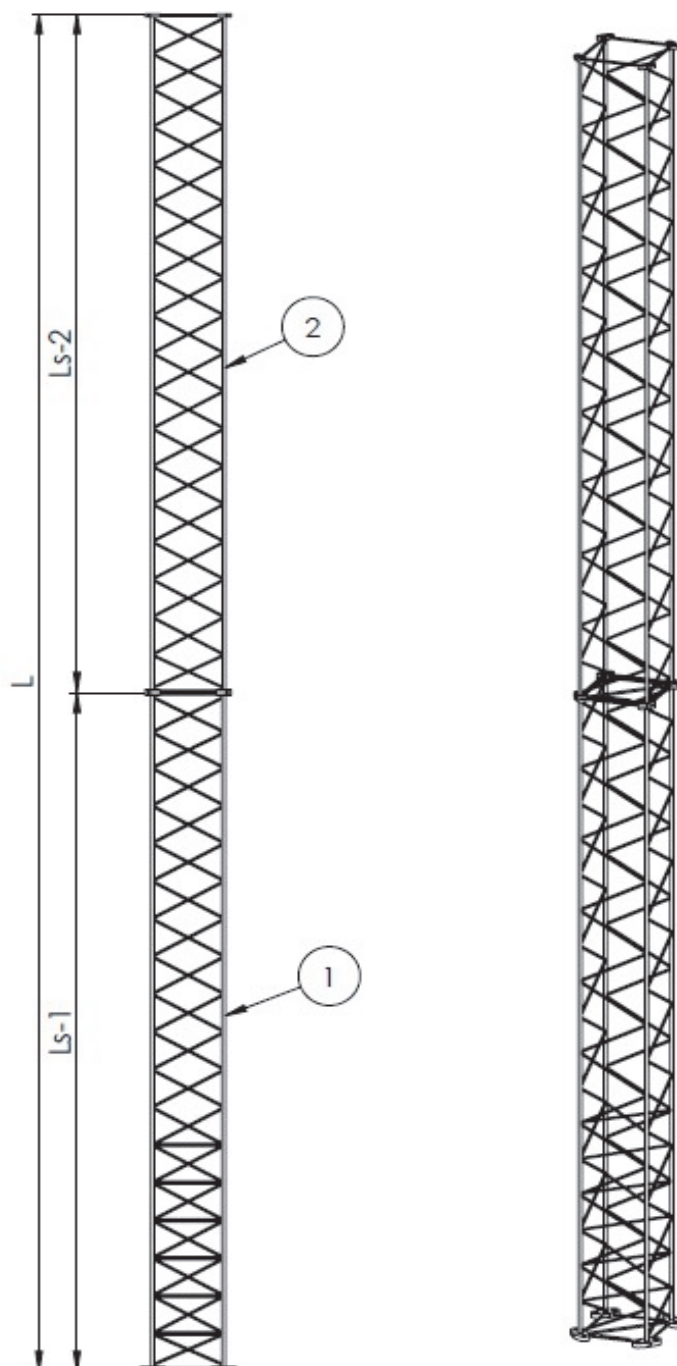

Geometri fra 3D CAD-modellen er ledende med mindre annet er oppgitt på 2D tegning eller i tilleggsspesifikasjon

Kopiering av dette dokumentet, g det til andre og eller kommunikasjon av innholdet er forbudt uten særskilt fullmakt. Overretelse vil kunne medføre straff og/eller erstatningsansvar i henhold til gjeldende lov. Alle rettigheter er reservert i tillegg en innleggelse av patent og/eller annen registrering av immatrelle rettigheter.

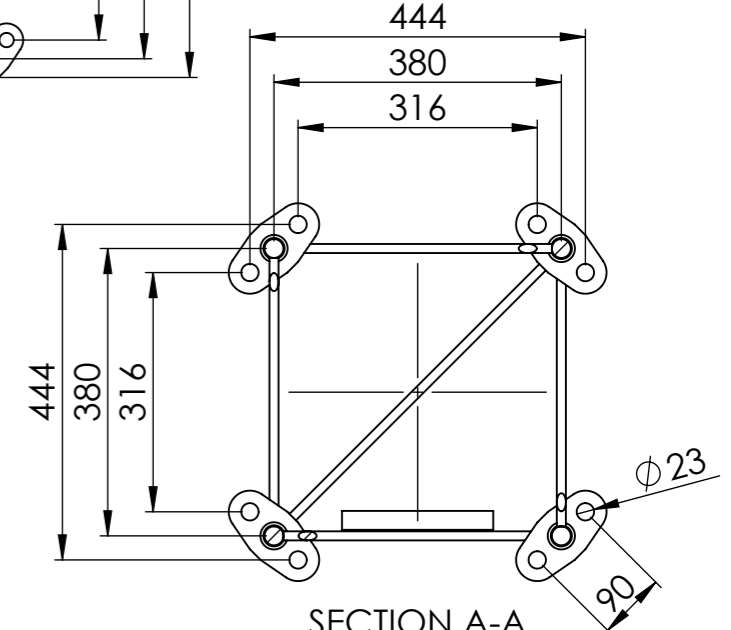
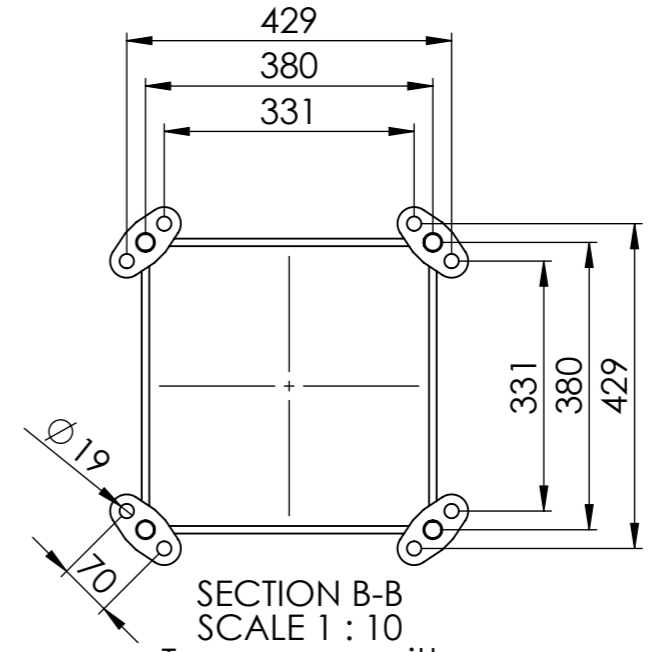
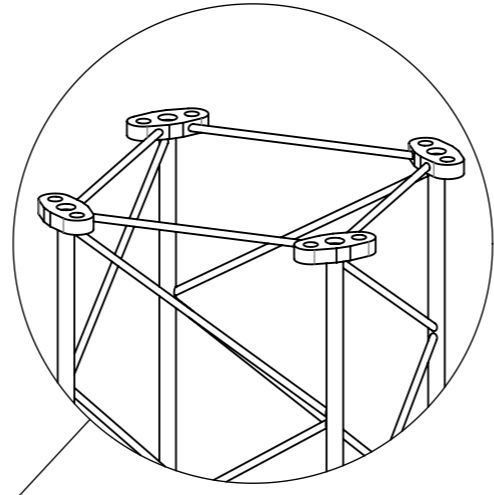
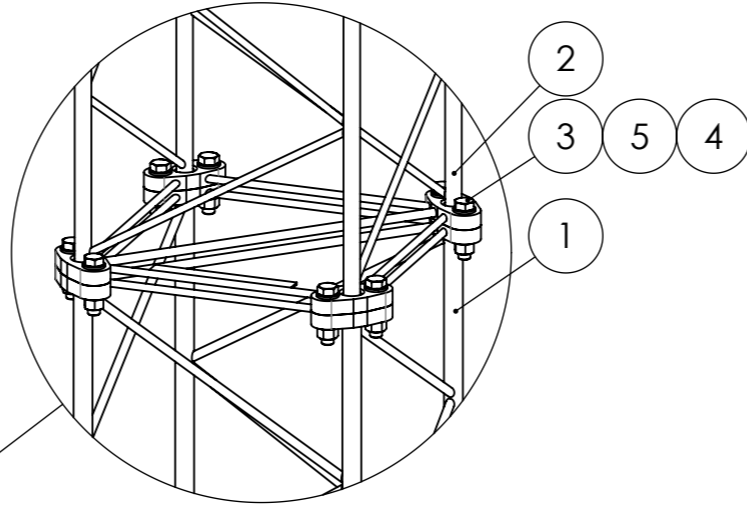
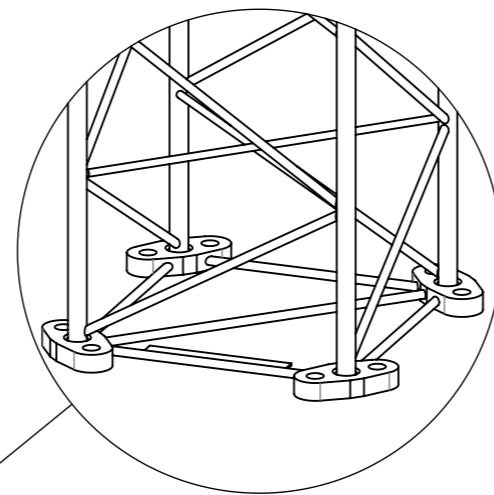
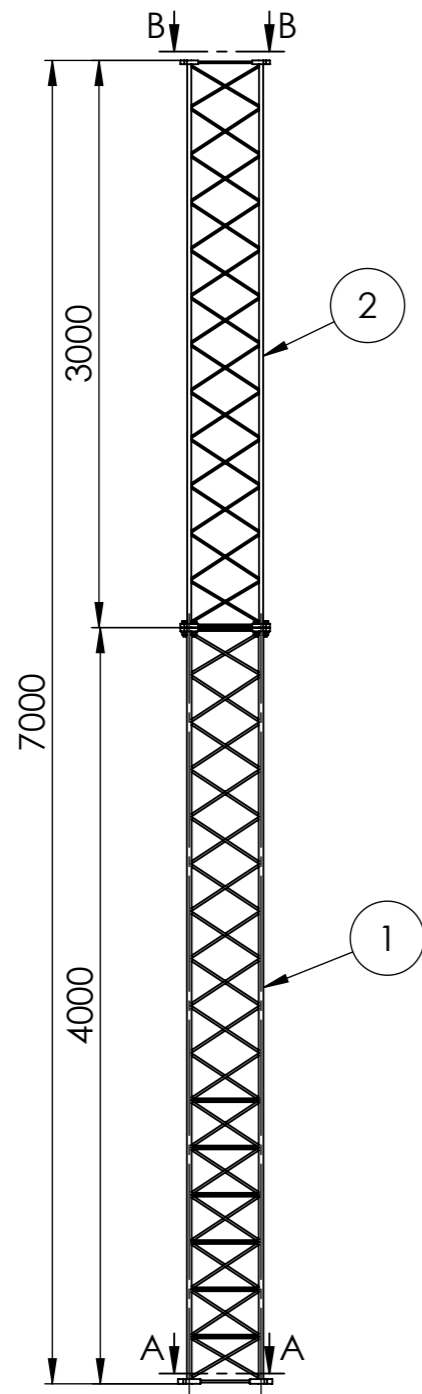

\*Hver seksjon er merket i henhold til "Merking" i tabell.  
 02821 = 5 siste siffer i tegningsnummer i sammenstillingstegning  
 ST = Saferoad Traffic AS  
 YY = Produksjons år  
 SP#### = Produsentens internnummer.  
 Siste siffer er posisjonsnummer på denne tegning.

Pos.	Ant.	Tegningsnummer	Beskrivelse	Materiale	Artikkelnummer	Merking	Vekt
5	16		Skive ISO 7089 - 16	8.8 HDG			0.0
4	8		Sekskantmutter ISO 4032 - M16	8.8 HDG			0.0
3	8		Sekskant hode bolt ISO 4014, M16x70 8.8 SB HDG	8.8 HDG			0.2
2	1	10002825	ST Kameramast, 380 3m, Toppseksjon, Sveisetegning	S355	22590013803	02821STYYSP####-2	55.1
1	1	10002829	ST Kameramast, 380 4m, Bunnseksjon, Sveisetegning	S355	22590013840	02821STYYSP####-1	99.3

Tegnet dato	Tegner	Godkjent dato	Godkjent av	Generell Toleranse	Projeksjon	Side	Skala
30.09.2020	REM	10.06.2024	JSK	-	1 av 1	1:40	
Material				Overflatebehandling	Vekt	Prod. gruppe	Format
					156.1kg	225	A3

Tittel	Status	Tegningsnr.	Revisjon
ST Kameramast, 380 7m, Sammenstilling	IFC	10002821	2
Tilleggsbeskrivelse	Artikkelnr.	Prosjektnr.	Dokument Type
	22512023807		

**Fundamentering: 380x380 2M20**





Ytelseserklæring:  
[saferoad.no/ye/225](http://saferoad.no/ye/225)

**CE**  
**2627**

## **Saferoad Traffic AS**

Paul A. Owrens veg 46  
2607 Vingrom  
+47 61 24 80 50  
[www.saferoad.no](http://www.saferoad.no)

20

225.02821-CPR-2020.10.05

NS-EN 1090-1:2009+A1:2011

### **Antenne-Kamera mast 380 7m to-delt**

Tolerances: NS-EN1090-2 , class 1  
Weldability: S355J2 according to EN10025-2  
Fracture toughness: S355J2: 27J at temp. -20°  
Cadmium extraction: NPD  
Radioactivity: NPD  
Durability: HDG acc. to SS-EN ISO 1461,  
class Fe/Zn 115µm

### **Structural characteristics**

Fatigue strength: Not analyzed  
Resistance to fire: NPD  
Execution class: EXC2

Manufacturing: Drawing no.:  
10002821

Product number: 22512023807

Marking: 02821STÅSP####

# CERTIFICATE

conformity of the Factory Production Control

**2627-CPR-1090-1.PL0238.TÜVRh.22.01**

In compliance with Regulation 305/2011/EU of the European Parliament and of the Council of 9 March 2011 (the Construction Products Regulations - CPR)

This certificate applies to the following construction product:

<b>Construction product</b>	Structural components and kits for steel structures to EXC2 according to EN 1090-2:2018
<b>Intended use</b>	for load-bearing structures in all types of buildings
<b>CE-marking method</b>	ZA.3.2-ZA.3.5 according to EN 1090-1:2009+A1:2011
<b>Manufacturer</b>	<b>Saferoad Traffic AS</b> Paul A. Owrens veg 46 2607 Vingrom Norway
<b>Manufacturing plant</b> <small>Production facility of the manufacturer</small>	Saferoad Pomerania Sp. z o.o. Stanisława Dubois 23 str. 71-610 Szczecin, Poland
<b>Confirmation</b>	This certificate attests that all provisions concerning the assessment and verification of constancy of performance described in Annex ZA of the harmonised standard  EN 1090-1:2009+A1:2011 under system 2+ are applied and that the factory production control is assessed to be in conformity with the applicable requirements.
<b>Date of first issue</b>	21.06.2018
<b>Validity</b>	This certificate will remain valid as long as neither the harmonised standard, the construction product, the AVCP methods nor the manufacturing conditions in the plant are modified significantly, unless suspended or withdrawn by the notified factory production control certification body.
<b>Next Surveillance inspection</b>	20.06.2025
<b>Place and date of issue</b>	Zabrze, 15.03.2024

*Leszek Zadroga*  
Leszek Zadroga  
Notified Body

# WELDING CERTIFICATE

## 8610-1090-2.PL0150.TÜVRh.22.01

in accordance with EN 1090-1:2009+A1:2011, table B.1 for execution of structural steel components EN 1090-2:2018

<b>Manufacturer</b>	<b>Saferoad Traffic AS</b> Paul A. Owrens veg 46 2607 Vingrom Norway
<b>Manufacturing plant</b> <small>Production facility of the manufacturer</small>	Saferoad Pomerania Sp. z o.o. Stanisława Dubois 23 str. 71-610 Szczecin, Poland
<b>Technical specification</b>	EN 1090-2:2018
<b>Execution class(es)</b>	EXC2 acc. to EN 1090-1:2009+A1:2011
<b>Welding Process(es)</b> <small>(Reference no acc. to EN ISO 4063)</small>	135 - Metal active gas welding, partly mechanized
<b>Material group</b>	1.1, 1.2, 1.3 according to CEN ISO/TR 15608
<b>Responsible welding coordinator</b>	PL-IWE-00757/2010
<b>Confirmation</b>	All provisions concerning welding as described in the above mentioned technical specification(s) were applied.
<b>Begin of validity</b>	21.06.2018
<b>Period of validity</b>	20.06.2025
<b>Place and date of issue</b>	Zabrze, 15.03.2024

*Leszek Zadroga*



Leszek Zadroga  
Certification Body



 **TÜVRheinland**<sup>®</sup>  
Precisely Right.

## 225.F380 2M20 2,0m-CPR-2024.02.02

Utført av JSK - Godkjent for produsent av Dag Riise 02.02.2024

<b>Produkt:</b>	<b>ST portalfundament 380x380 2M20 2.0m</b>
<b>Produkt nummer:</b>	22595001310
<b>Påtenkt bruk:</b>	Fundament til Saferoad trafikkportal
<b>Harmonised Standard:</b>	EN 14991:2007
<b>Produsent / Plassert på markedet av:</b>	Saferoad Traffic AS Paul A. Owrens veg 46, 2607 Vingrom, Norway
<b>Produsert på fabrikk:</b>	Skjæveland Gruppen AS, N-4323 Sandnes, Norway
<b>Beregningsmetode:</b>	Broms metoden (Bengt B. Broms)
<b>Teknisk spesifikasjon: Harmonisert standard NS EN 14991:2007</b>	<p>Fundamentet produseres i hht. betongstandard NS-EN 206-1</p> <p>Betong: Fasthetsklasse NS B-55 med sluttresultat <math>f_{ck} = 67 \text{ N/mm}^2</math>, testet på terning 100x100mm. Eksponeringsklasse XD 1, 2, 3. Testet på sylinder skal sluttresultatet være min. <math>55 \text{ N/mm}^2</math>.</p> <p>Sementmengde min. 300 kg pr <math>\text{m}^3</math>. Masseforhold maks. M-45.</p> <p>Vannabsorpsjon: Etter 30 m. maks. 3,0 %. Etter 24 t. maks. 5,0 %.</p> <p>Armering: B500SP / B500B, <math>f_{tk} = 600 \text{ N/mm}^2</math>, <math>f_{yk} = 500 \text{ N/mm}^2</math></p> <p>Fotplater og hjørnstag: S355J2</p> <p>Varmforsinket iht. EN ISO 1461, klass Fe/Zn 115<math>\mu\text{m}</math></p> <p>Armering, Ytelseserklæring: 225.A380 2M20 2,0m-CPR-2024.03.03</p> <p>Løfteanker: 2 stk. Congrip (4,0) 3-065G</p> <p>Festemateriell, varmforsinkede bolter som leveres med fundamentet:</p> <p>8 stk. M20x90mm 6kt.bolt ISO4014, VZN SB 8.8</p> <p>16 stk. M20 Skive ISO 7089, VZN 8.8</p> <p>16 stk. M20 Skive ISO 7089, VZN 8.8</p> <p>Festemateriell, bolter i kvalitet A4-80 kan bestilles til/med fundamentet.</p>
<b>Vekt:</b>	1238,7 kg
<b>Produksjonsgrunnlag:</b>	Saferoad Traffic AS produkt nr.: 22595001310 Tegningsnr.: 10002436 (Armering, Tegningsnr.: 10002437)
<b>Montering:</b>	Se monteringsveiledning på <a href="http://saferoad.no/mv/225">saferoad.no/mv/225</a> Samt illustrasjoner med mål på side 2.
<b>Drift / Vedlikehold:</b>	Varmforsinkede fundamentbolter kontrolleres og skiftes ev. ut ved behov, ca. hvert 10:e år. Intet vedlikehold dersom A4-80 bolter brukes.
<b>Systemer for vurdering og kontroll, CE merking:</b>	Fundamentet er CE merket i hht. EN 14991:2007, se vedlegg. <b>Notified body nr. 1111, Kontrollrådet</b> , se vedlagt sertifikat. System for attestering av samsvar: System 2+
<b>Merking:</b>	<p><b>På stål:</b> 380-2M20-2,0mSTÅÅSP##### (ÅÅ = prod.år, ##### = SP internt order nr.)</p> <p><b>På betong:</b> <b>ST 22595001310</b> <b>380x380 2M20</b> <b>2,0m 1,3t</b></p> <div style="display: flex; align-items: center; justify-content: center;">   </div>

## 225.F380 2M20 2,0m-CPR-2024.02.02

Utført av JSK - Godkjent for produsent av Dag Riise 02.02.2024

### ST portalfundament 380x380 2M20 2.0m

Prefabrikkert 2,0m betongfundament for portal

2M20 betegner at det benyttes 2 stk. M20 bolter i hvert hjørne, 8 stk. bolter totalt

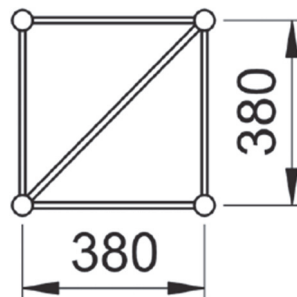
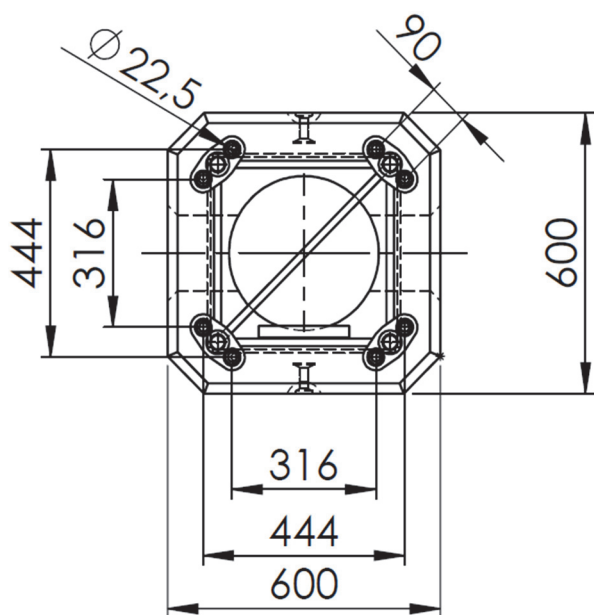
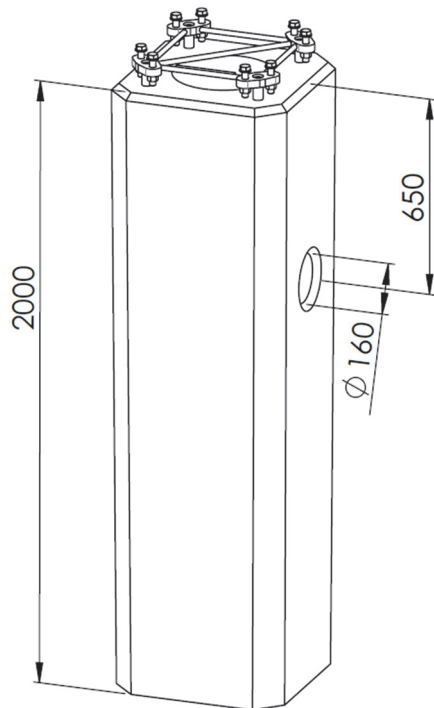





Ytelseserklæring:  
saferoad.no/ye/225/Fund



Monteringsveiledning:  
saferoad.no/mv/225

## Saferoad Traffic AS

Paul A. Owrens veg 46  
2607 Vingrom  
+47 61 24 80 50  
www.saferoad.no

20

225.F380 2M20 2,0m-CPR-2024.02.02

NS EN 14991:2007

### ST portalfundament 380x380 2M20 2.0m

Vekt: 1238,7 kg

Betong: NS B-55,

$$f_{ck} = 67 \text{ N/mm}^2$$

Armering: B500SP / B500B

$$f_{yk} = 500 \text{ N/mm}^2$$

$$f_{tk} = 600 \text{ N/mm}^2$$

Fotplater og hjørnstag: S355J2

Varmforsinket iht. EN ISO 1461, klass Fe/Zn 115µm

Tegningsnummer: 10002436

ST Produktnummer: 22595001310

Armering, Tegningsnummer: 10002437

Armering, ST Produktnummer: 22590002310

Armering Ytelseserklæring:

225.A380 2M20 2,0m-CPR-2024.03.03

Merking stål: 380-2M20-2,0mSTÅÅSP####



## CERTIFICATE

### Conformity of the Factory Production Control

**1111-CPR-0558**

In compliance with Regulation 305/2011/EU of the European Parliament and of the Council of 9 March 2011 (the Construction Products Regulation or CPR), this certificate applies to the construction product

**Precast concrete products. Foundations : EN 14991 : 2007**

**Precast concrete foundationproducts: Euroskilt Bommer, Portaler, Halvportaler Norsafe® Mast Optimized foundations Low type 1, types: F-NM89-7.5L; F-NM120-15L; F-NM150-30L; F-NM190-45L; F-NM190-60L; F-NM290-100L and Norsafe® Mast foundations High type 2, types: F-NM89-7.5H; F-NM120-15H; F-NM150-30H; F-NM190-45H; F-NM190-60H; F-NM290-100H**

Produced by or for

**Saferoad Traffic AS**

**Paul A Owrens Veg 46**

**N - 2607 Vingrom, Norway**

and produced in manufacturing plant(s)

**Skjæveland Gruppen AS, N-4323 Sandnes, Norway**

This certificate attests that all provisions concerning the assessment and verification of constancy of performance described in Annex ZA of the standard(s)

**EN 14991:2007**

under system 2+ are applied and that the factory production control fulfils all the prescribed requirements set out above.

This certificate was first issued on 06.01.13 and will remain valid as long as the test methods and/or factory production control requirements included in the harmonised standard, used to assess the performance of the declared characteristics, do not change, and the product, and the manufacturing conditions in the plant are not modified significantly. The certificate will expire at the latest **30.09.25**.

Oslo, 19. January 2024

Certification Manager